

Energy Harvesting Sensor Nodes: Survey and Implications

Sujesha Sudevalayam

Purushottam Kulkarni

December 19, 2008

Abstract

Sensor networks with battery-powered nodes can seldom simultaneously meet the design goals of lifetime, cost, sensing reliability and sensing and transmission coverage. *Energy-harvesting*, converting ambient energy to electrical energy, has emerged as an alternative to power sensor nodes. By exploiting recharge opportunities and tuning performance parameters based on current and expected energy levels, energy harvesting sensor nodes have the potential to address the conflicting design goals of lifetime and performance. This paper surveys various aspects of energy harvesting sensor systems— architecture, energy sources and storage technologies and examples of harvesting-based nodes and applications. The study also discusses the implications of recharge opportunities on sensor node operation and design of sensor network solutions.

1 Introduction

Technological developments over the last decade have yielded several specialized embedded platforms capable of sensing, computing and communication. A direct consequence of these developments has been the emergence of, and subsequent large-scale research and engineering focus in, the area of sensor networks. A sensor network is a network of embedded devices (sensor nodes) operating in a co-operative manner to sense and collect data for application-specific analysis. A sensor network application has several design dimensions, sensing modality (type of sensor to use), computation, communication and storage capabilities, cost and size of each node, type of power source, architecture for deployment, protocols for data dissemination and communication, applications and management tools, to name a few.

A typical and widely deployed application category is one that uses battery-powered sensor nodes. A few instantiations of such deployments are for applications such as, *Habitat monitoring* [29] — environmental monitoring in wild-life habitats like Great Duck Island and James Reserve, to study weather conditions and animal migratory patterns, *Volcano monitoring* [47] — network of seismometers used in a time-synchronized and event-triggered manner to measure volcanic activity, *Structural monitoring* [25, 5] — BriMon, a sensor network to detect incoming trains and measure the forced and free vibrations of a bridge; and *Vehicle tracking* [20] — sensors placed along or on roads, and on vehicles, detect road, traffic and environmental conditions—information which can be used to warn drivers of potentially dangerous conditions or to inform about traffic conditions for better route planning.

As seen in applications mentioned above, battery-powered untethered sensor nodes can be used to instantiate applications in remote hard-to-reach locations and locations where power lines do not exist. Further, being untethered, placement of these nodes is practically unrestricted and their movement unrestrained. A tradeoff of these benefits is the finite battery capacity—nodes will operate for a finite period of time, that is, only as long as the battery lasts. Finite node lifetime implies finite lifetime of the applications or, additional cost and complexity to regularly change batteries. Nodes could possibly use large batteries for longer lifetimes, but will have to deal with increased size, weight and cost. Nodes may also opt to use low-power hardware like low-power processor and radio, at the cost of lesser computation ability and lower transmission ranges, respectively.

Several solution techniques have been proposed to maximize the lifetime of battery-powered sensor nodes. Some of these include energy-aware MAC protocols (SMAC [48], BMAC [36], XMAC [4]), power

aware storage, routing and data dissemination protocols [12, 15, 7], duty-cycling strategies [10, 8], adaptive sensing rate [28], tiered system architectures [11, 21, 22] and redundant placement of nodes [44, 23] to ensure coverage guarantees. While all the above techniques optimize and adapt energy usage to maximize the lifetime of a sensor node, the lifetime remains bounded and finite. The above techniques help prolong the application lifetime and/or the time interval between battery replacements but do not help discard energy-related inhibitions. With a finite energy source, seldom can all the performance parameters be optimized simultaneously, e.g., higher battery capacity implies increased cost, low duty-cycle implies decreased sensing reliability, higher transmission range implies higher power requirement and lower transmission range implies transmission paths with more number of hops resulting in energy usage at more number of nodes.

An alternative technique that has been applied to address the problem of finite node lifetime is the use of *energy harvesting*. Energy harvesting refers to harnessing energy from the environment or other energy sources (body heat, foot strike, finger strokes) and converting it to electrical energy. The harnessed electrical energy powers the sensor nodes. If the harvested energy source is large and periodically/continuously available, a sensor node can be powered perpetually. Further, based on the periodicity and magnitude of harvestable energy, system parameters of a node can be tuned to increase node and network performance. Since, a node is energy-limited only till the next harvesting opportunity (recharge cycle), it can optimize its energy usage to maximize performance during that interval. For example, a node can increase its sampling frequency or its duty-cycle to increase sensing reliability, or increase transmission power to decrease length of routing paths. A node can afford to change its system parameters at the risk of higher power consumption, since it is energy constrained only till the next recharge cycle. As a result, energy harvesting techniques have the potential to address the tradeoff between performance parameters and lifetime of sensor nodes. The challenge lies in estimating the periodicity and magnitude of the harvestable source and deciding which parameters to tune and simultaneously avoiding premature energy depletion before the next recharge cycle.

As part of this study, we present details energy harvesting techniques—architectures, energy sources, storage technologies and examples of applications and network deployments. Further, as mentioned above, sensor nodes can exploit energy harvesting opportunities to dynamically tune system parameters. These adaptations have interesting implications on the design of sensor network applications and solutions, which we discuss. As contributions of this study we present and discuss,

- basics of energy harvesting techniques,
- details of energy sources used for harvesting and corresponding energy storage technologies,
- energy harvesting architectures,
- examples of energy harvesting systems and applications based on these systems and
- implications of energy harvesting on design of sensor network applications and solutions.

The rest of the paper is organized as follows, Section 2 describes basic concepts, components and types of energy harvesting nodes. Examples of energy harvesting sensor nodes and related applications are presented in Section 3. Section 4 presents implications of harvestable energy on sensor network applications and solutions design. Section 5 concludes.

2 Energy Harvesting Sensor Nodes

Energy harvesting refers to scavenging energy or converting energy from one form to the other. Applied to sensor nodes, energy from external sources can be harvested to power the nodes and in turn, increase their lifetime and capability. Given the energy-usage profile of a node, energy harvesting techniques could meet partial or all of its energy needs. A widespread and popular technique of energy harvesting is converting solar energy to electrical energy. Solar energy is uncontrollable—the intensity of direct sunlight cannot be controlled—but it is a predictable energy source with daily and seasonal patterns.

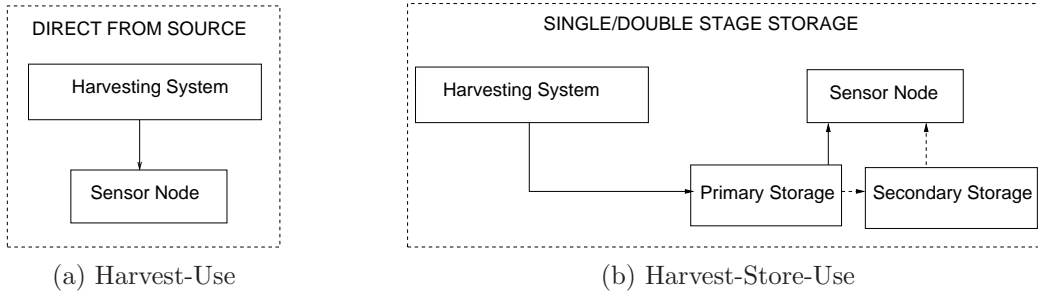

Figure 1: Energy harvesting architectures with and without storage capability.

Other techniques of energy harvesting convert mechanical energy or wind energy to electrical energy. For example, mechanical stress applied to piezo-electric materials, or to a rotating arm connected to a generator, can produce electrical energy. Since the amount of energy used for conversion can be varied, such techniques can be viewed as controllable energy sources.

A typical energy harvesting system has three components, the Energy source, the Harvesting architecture and the Load. *Energy source* refers to the ambient source of energy to be harvested. *Harvesting architecture* consists of mechanisms to harness and convert the input ambient energy to electrical energy. *Load* refers to activity that consumes energy and acts as a sink for the harvested energy.

2.1 Energy Harvesting Architectures

Broadly, energy harvesting can be divided into two architectures— (i) *Harvest-Use*: Energy is harvested just-in-time for use and (ii) *Harvest-Store-Use*: Energy is harvested whenever possible and stored for future use.

2.1.1 Harvest-Use Architecture

Figure 1(a) shows the *Harvest-Use* architecture. In this case, the harvesting system directly powers the sensor node and as a result, for the node to be operational, the power output of the harvesting system has to be continuously above the minimum operating point. If sufficient energy is not available, the node will be disabled. Abrupt variations in harvesting capacity close to the minimum power point will cause the sensor node to oscillate in ON and OFF states.

A *Harvest-Use* system can be built to use mechanical energy sources like pushing keys/buttons, walking, pedaling, etc. For example, the push of a key/button can be used to deform a piezo-electric material, thereby generating electrical energy to send a short wireless message. Similarly, piezo-electric materials strategically placed within a shoe may deform to different extents while walking and running. The harvested energy can be used to transmit RFID signals, used to track the shoe-wearer.

2.1.2 Harvest-Store-Use Architecture

Figure 1(b) depicts the *Harvest-Store-Use* architecture. The architecture consists of a storage component that stores harvested energy and also powers the sensor node. Energy storage is useful when the harvested energy available is more than the current usage. Excess energy is stored for later use when either harvesting opportunity does not exist or energy usage of the sensor node has to be increased to improve capability and performance parameters. The storage component itself may be single-stage or double-stage. *Secondary storage* is a backup storage for situations when the *Primary storage* is exhausted.

As an example, a *Harvest-Store-Use* system can use uncontrolled but predictable energy sources like solar energy. During the daytime, energy is used for work and also stored for later use. During night, the stored energy is conservatively used to power the sensor node.

Energy Source	Characteristics
Solar	Ambient, Uncontrollable, Predictable
Wind	Ambient, Uncontrollable, Predictable
RF Energy	Ambient, Partially controllable
Body heat, Exhalation, Breathing and Blood Pressure	Passive human power, Uncontrollable, Unpredictable
Finger motion and Footfalls	Active human power, Fully controllable
Vibrations in indoor environments	Ambient, Uncontrollable, Unpredictable

Table 1: Listing and characterization of energy sources.

2.2 Sources of Harvestable Energy

A vital component of any energy harvesting architecture is the energy source—it dictates the amount and rate of energy available for use. Energy sources have different characteristics along the axes of controllability, predictability and magnitude[17]. A *controllable* energy source can provide harvestable energy whenever required, energy availability need not be predicted before harvesting. With *non-controllable* energy sources, either energy may be simply harvested whenever available or, harvesting opportunities may be scheduled to coincide with the energy availability periods (hourly, daily, weekly, etc.). A prediction model which forecasts the availability of the energy source can be used for scheduled harvesting and also as an input to indicate the time of next recharge cycle. Further, energy sources can be broadly classified into the following two categories, (i) *Ambient Energy Sources*: Sources of energy from the surrounding environment, e.g., solar energy, wind energy and RF energy, and (ii) *Human Power*: Human power refers to the energy harvested from body movements of humans [42, 39, 24, 32]. Passive human power sources are those which are not user controllable. Some examples are blood pressure, body heat and breath[42]. Active human power sources are those that are under user control, and the user exerts a specific force to generate the energy for harvesting, e.g., finger motion, paddling and walking[42].

Table 1 tabulates characteristics of different energy sources as *fully controllable*, *partially controllable*, *uncontrollable but predictable* and *uncontrollable and unpredictable*. Solar energy, the most promising of the harvestable energy sources, is uncontrollable but predictable—daily and seasonal, sunrise and sunset timings can be fairly accurately estimated. Rotating a coil in a magnetic field to produce energy, is an example of a fully controllable energy source.

2.3 Energy Conversion Mechanisms

This refers to the mechanism for scavenging electrical energy from a given energy source and all energy sources can not be harnessed by the same mechanism. That is, the choice of energy conversion mechanism is closely tied to the choice of energy source. In case of solar energy, the conversion mechanism is the use of solar panels. A solar panel acts like a current source and its size/area is directly proportional to the amount of current generated. Hence, depending upon the requirements, bigger or more number of solar panels are employed. In case of mechanical sources of energy like walking, paddling, pushing buttons/keys, the conversion to electrical energy is done using piezo-electric elements. Piezo-electric films and ceramics deform on application of force and generate electric energy. Larger the size of the film, larger is the amount of energy harvested. Wind energy is harvested using rotors and turbines that convert circular motion into electrical energy by the principle of electromagnetic induction. Section 3

Technology	Energy Density (MJ/kg)	Power Density (W/kg)	Efficiency (%)	Discharge Rate (% per month)	Recharge Cycles
Sealed Lead Acid	0.11-0.14	180	70-92	3-4	500-800
Ni-cadmium	0.14-0.22	150	70-90	20	1500
NiMH	0.11-0.29	250-1000	66	20	1000
Li-ion	0.58	1800	99.9	5-10	1200

Table 2: Comparison of rechargeable battery technologies

presents details of various energy sources and systems that use these energy sources.

2.4 Storage Technologies

Since the storage technology partially governs the efficiency of energy harvesting, choice of the storage component and the corresponding recharge technology is of prime significance for energy harvesting systems. Rechargeable batteries, a common choice of energy storage, are made up of several technologies (chemical compositions). A rechargeable battery is a storage cell that can be charged by reversing the internal chemical reaction. A few of the popular rechargeable technologies are Sealed Lead Acid (SLA), Nickel Cadmium (NiCd), Nickel Metal Hydride (NiMH) and Lithium Ion (Li-ion). These battery technologies can be characterized along several axes — energy density, power, storage efficiency, discharge rate and number of deep recharge cycles¹.

Table 2 shows typical values of the above parameters across different battery technologies. Nominal voltages for SLA, NiCd, NiMH and Li-ion batteries are 6, 1.2, 1.2 and 3.6 volts, respectively. Table 2 shows that lithium ion batteries have highest output voltage, energy density, power, efficiency. Though NiMH has better energy density and power density than NiCd, but NiCd has high number of deep recharge cycles. Sealed Lead Acid has the lowest values for energy density, power and number of cycles and hence is the least effective storage technology.

From the perspective of using batteries for storing harvested energy, the Li-ion storage technology appears to be the best. These batteries have high output voltage, energy density, efficiency and moderately low self-discharge rates². Another advantage of Li-ion batteries is that they do not suffer from *memory effect*—loss of energy capacity due to repeated shallow recharge³. However, Li-ion batteries require *pulse-charging* for recharge—a high pulsating charging current. Usually an auxiliary battery or a charging circuit is required for this purpose.

Another popular battery technology is Nickel-Metal Hydride. NiMH batteries have reasonably high energy, power density and recharge cycles. An advantage of NiMH batteries is that they can be *trickle* charged, i.e., directly connected to an energy source for charging. Though NiMH batteries suffer from memory effect, the effect is reversible by conditioning—fully discharging the battery after charging it.

Alternatively, super-capacitors can be used instead of or along with rechargeable batteries as storage components. Like batteries, super-capacitors also store charge, but they self-discharge at a higher rate than batteries. Theoretically, super-capacitors have infinite recharge cycles, and therefore have no limit to the number of times they can undergo deep recharge [16].

3 Energy Harvesting Sensor Nodes and Applications

This section describes implementations of energy harvesting sensor nodes designed to use various energy sources such as solar energy [17, 37, 14, 16, 40, 41, 33], active user power [42, 32, 39, 24, 31], wind energy [46, 33] and RF energy [2, 45].

¹Deep recharge cycle refers to the cycle of recharging the battery after a complete drainout

²Self-discharge is the loss of battery capacity while it simply sits on the shelf.

³Shallow recharge refers to recharging a partially discharged battery.

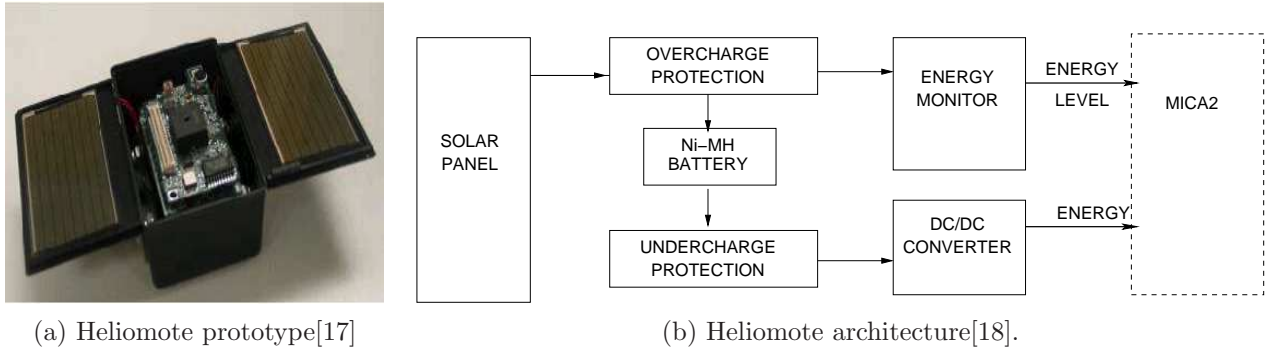

Figure 2: Photo of Helimote prototype and the Helimote architecture.

3.1 Solar Energy Harvesting Systems

In this sub-section, we describe some implementations of solar energy harvesting sensor node namely, Helimote, Prometheus, Everlast, Sunflower and Ambimax. Of these, the first four are purely solar energy harvesting systems whereas Ambimax attempts to harvest from both solar and wind energy sources. These solar energy harvesting implementations are different along axes like characteristics of solar panels, battery type and capacity, and complexity of recharge circuit.

3.1.1 Helimote

Helimote[17] is a single-storage energy harvesting system for scavenging solar energy, built using the Mica2 platform [13, 1]. Figure 2 shows a picture of the Helimote prototype and its system architecture.

Helimote uses a solar panel of area 3.75 inches x 2.5 inches which outputs 60mA at a voltage of 3.3V. The power from this solar panel is used to recharge two AA-sized Ni-MH battery of capacity 1800mAh each. Overcharging a Ni-MH battery can lead to instability and is very hazardous, and so an overcharge protection circuit is used. Similarly, undercharging the Ni-MH battery is prevented so that the load does not continue drawing power even after the battery voltage has dropped below a low threshold. Such undercharging is not only wasteful of energy (since power is not enough to drive the micro-controller) but can also cause damage to the rechargeable batteries. In Helimote, both the over-charge and under-charge protection modules are hardware components (control circuits) consisting of comparator with hysteresis, that control analog switches.

Helimote also has an energy monitoring component which enables a sensor node to learn its energy availability and usage. The Energy Monitor component of the Helimote measures and conveys information regarding the amount and variance of energy extracted. The Helimote analysis suggests that if the battery size is enough to accommodate the variability in extracted energy and the rate of consumption of power is less than the rate of sourced power, then perpetual operation can be achieved. A thorough and complete mathematical analysis of these conditions is presented in [17]. Further, information from the energy monitoring component can be used by the micro-controller to perform harvesting-aware performance adaptation. Section 4 discusses in more detail the implications of energy harvesting on wireless sensor node applications.

3.1.2 Prometheus

Prometheus [16] is a double-storage energy harvesting system for scavenging solar energy, built using the TelosB platform[1, 35]. The Prometheus node is powered by the primary buffer which gets replenished when solar energy is available. The primary buffer also charges the secondary buffer when excess energy is available. On the other hand, once the primary buffer energy falls below a threshold, the node falls back to the secondary buffer until primary buffer gets sufficiently recharged again. The block diagram for Prometheus is shown in Figure 3.

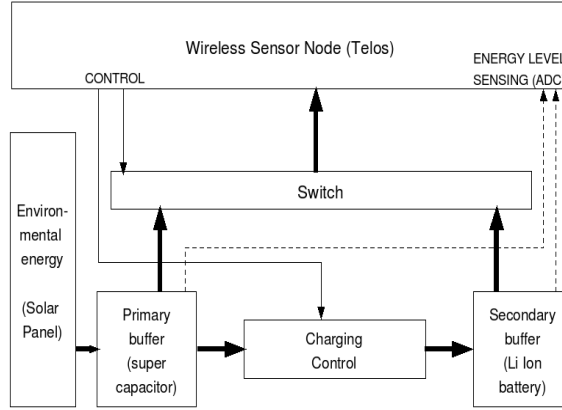

Figure 3: Prometheus energy harvesting architecture [16].

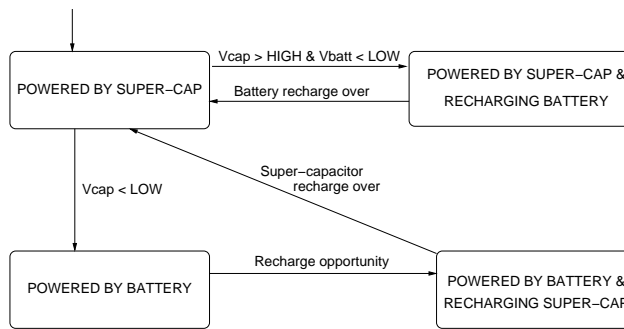

Figure 4: State diagram of Prometheus driver.

As seen in Figure 3, the basic components of the Prometheus system architecture are the solar energy source, primary energy buffer (super-capacitor), secondary energy buffer (Li-ion battery), charge controller and power switch interfaced to the Telos sensor node. Compared to the architecture of Helimote, the major differences in the Prometheus energy harvesting architecture is that there is an additional stage of storage, and the charging control is accomplished in software.

The reason for using double stage storage in Prometheus is as follows. The storage component in Helimote[18] is realized as a rechargeable battery. As we have already discussed in Section 2.4, all rechargeable battery technologies have a limited number of deep recharge cycles. Hence, it is preferable that the battery have more shallow recharge cycles rather than deep ones. However, the NiMH battery used in Helimote can suffer from memory effect when it undergoes many shallow recharge cycles, which is also undesirable. Due to these considerations, Prometheus uses the first-stage storage consisting of super-capacitors and the second-stage storage consisting of a Li-ion battery. Since super-capacitors can undergo infinite recharge cycles, using them as the primary energy source can minimize access to the battery. Whenever solar energy is available, the node is powered by the super-capacitor and the Li-ion battery is used only when such opportunity does not exist—during nights, cloudy days, etc. Hence, battery does not discharge full and shallow recharge occurs.

Prometheus has a software driver to manage the charging of the energy storage buffers and the switching between them to power the node. The *Switch* block shown in Figure 3 is used to switch between the two power sources — the *super-capacitor* and the *lithium ion battery* — for powering the Telos. Figure 4 depicts the logic implemented by the driver to switch between power sources.

As shown in the state diagram, so long as the super-capacitor charge is above a high threshold, it is used to power the node. If the super-capacitor charge is above the high threshold and the Li-ion battery charge is below a high threshold, then the battery is charged from the super-capacitor. If the

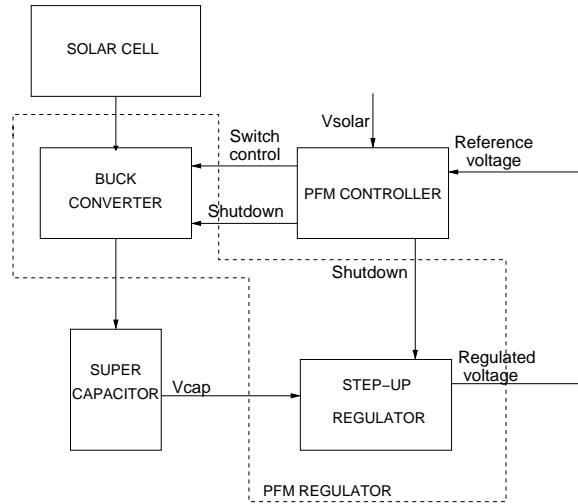

Figure 5: Block diagram of Everlast’s energy harvesting subsystem.

super-capacitor is below a low threshold and recharge opportunity is available, then the super-capacitor is charged. When recharge opportunity for capacitor is not available, then the node is powered from the Li-ion battery until it falls below the low threshold or until the super-capacitor subsequently gets recharged. As soon as energy becomes available again, the super-capacitor gets charged and on reaching a high threshold, the Li-ion battery gets charged from the super capacitor. This logic is implemented in TinyOS on the Prometheus.

3.1.3 Everlast

Everlast[40] is a supercapacitor-operated wireless sensor node. Unlike Heliomote and Prometheus, Everlast does not use batteries. Everlast claims to be operable at 50% duty cycle and 1Mbps data rates for 20 years, without maintenance. Everlast attempts to break the performance-lifetime trade off by using a 100F super-capacitor, low supply current MCU (PIC16LF747 - from $25\mu\text{A}$ at 31.25kHz to $930\mu\text{A}$ at 8MHz) and low power transceiver supporting 1Mbps data stream (Nordic nRF2401 - 0dBm power). Everlast is an integrated system with sensors, radio, micro-controller and the energy harvesting sub-system, unlike Heliomote and Prometheus, which are add-ons for existing platforms. Figure 5 shows the block diagram of the energy harvesting sub-system of Everlast.

As shown in Figure 5, the components of Everlast’s energy scavenging subsystem are: solar cell, super-capacitor, PFM controller and PFM regulator. Everlast uses a pulse frequency modulated (PFM) regulator to charge the super-capacitor. The function of the PFM regulator is to charge a capacitor and then transfer the energy to the output load capacitor. The PFM regulator consists of a buck converter and a step-up regulator. Connecting a super-capacitor directly to the solar panel results in the solar voltage falling to the super-capacitor voltage, instead of the super-capacitor charging up. The switched-capacitor circuit with the buck converter provides a mechanism to efficiently charge the super-capacitor. When the solar voltage exceeds the specified reference V_{MPP} , the PFM controller (comparator) pulses the PFM regulator, denoted as “Switch control” signal in Figure 5. The PFM controller “shuts down” the PFM regulator when the capacitor is fully charged. MPP (Maximal Power Point) is the voltage and current combination that maximizes power output under given sunlight and temperature conditions and V_{MPP} is the voltage at MPP.

Another implementation of a solar energy harvesting node is the Sunflower, described in [41]. It uses four photo diodes, a miniature super-capacitor (0.2F) and has a form-factor of 0.9 inch \times 1.2 inch. Similar to Everlast, Sunflower employs a switching regulator to charge the super-capacitor using the photo diodes.

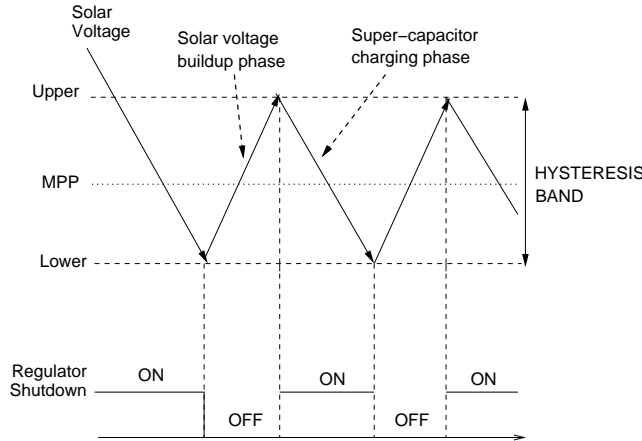

Figure 6: Super-capacitor charging using Maximal Power Point tracking and a switching regulator[33].

3.1.4 AmbiMax

AmbiMax[33] is a double-stage storage energy harvesting system. It is built using the Econode[34] platform and harvests solar and wind energy. However, its design is modular enough to accommodate other sources like water flow and vibration. In this section, we describe the solar energy harvesting sub-system of AmbiMax while Section 3.3 describes its wind energy harvesting sub-system.

Similar to Prometheus, AmbiMax has a primary storage (array of super-capacitors of 10F) and a secondary storage (Lithium polymer battery of 70mAh). Unlike Prometheus, the charging control of AmbiMax is accomplished via hardware and not in software. Also, each harvesting sub-system, related to each of the energy sources, has its own super-capacitor. AmbiMax performs MPPT (Maximal Power Point Tracking) autonomously, without software and MCU control. Instead of measuring the solar panel voltage, AmbiMax uses light intensity to control a PWM (Pulse Width Modulated) regulator for MPP tracking. The solar energy harvesting sub-system of AmbiMax includes the solar panel, a PWM switching regulator and MPPT circuitry. Figure 6 shows the working of MPPT using the comparator and the PWM switching regulator. When the solar voltage falls below the lower bound of the MPP hysteresis band, the regulator is switched off. It is switched back on only when the solar voltage rises and crosses the upper bound of the MPP hysteresis band. Using a PWM switching regulator between the solar panel and the super-capacitor ensures their isolation from each other—neither will the solar panel voltage fall to the supercapacitor voltage nor will there be a reverse current flow from the super-capacitor to the source. This helps in efficient charging of the supercapacitor.

3.1.5 Applications using Solar Energy Harvesting Sensor Nodes

Though energy harvesting sources are many, solar energy is the cheapest, most easily available and convenient source to harvest energy from. Hence, there is a host of applications [49, 3, 9, 30] that harvest solar energy for sustained operation. This section lists three representative applications.

- 1. ZebraNet.** *ZebraNet*[49] is a mobile sensor network with sparse network coverage and high-energy GPS sensors to track zebra movement. Continuous locating using GPS technology is done to track the long term animal migration patterns, habitats and group sizes. The ZebraNet collar prototype is shown in Figure 7(a). It weighs only a few hundred grams and outputs 0.4W in full sun[49]. The ZebraNet collar has 14 solar modules (each having 3 solar cells in series), a simple comparator and a boost converter. Each solar module produces maximum 7mA at 5V. The outputs of the solar modules are connected together in parallel, resulting in the addition of the power generated by each of them.

ZebraNet has a Li-ion rechargeable battery for support at night and bad weather, when a solar system would not suffice. The ZebraNet system is also a single-stage storage system, like the Heliomote. However,



(a) ZebraNet collar[49].



(b) eFlux node on a turtle[3].

Figure 7: ZebraNet and TurtleNet energy harvesting sensor nodes.

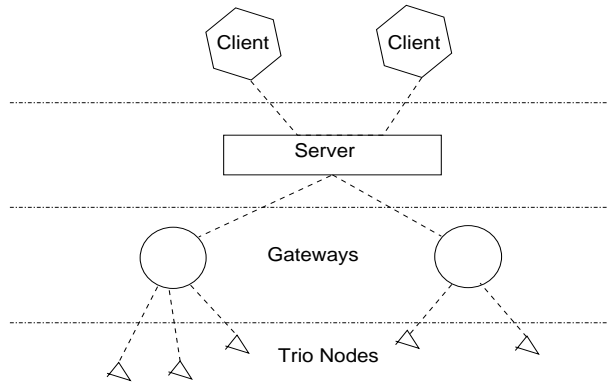

(a) Trio system hardware architecture.



(b) Trio node mounted on tripod.



(c) Trio gateway.

Figure 8: The three tier Trio system architecture and its components [9].

it uses software charging control for pulse-charging its 2Ah Li-ion battery⁴. The Li-ion battery provides the ZebraNet node 72 hours of operation when charged[49].

Similar to Everlast and Sunflower, ZebraNet is an integrated system. It uses the TI MSP430F149 micro-controller to manage the system operations. This micro-controller is also responsible for sensing the voltage level of the lithium-ion battery and pulse-charging it after voltage reaches 4.2V.

2. TurtleNet. *TurtleNet*[3] is a project with the goal of addressing the sensing and communication challenges related to the in-situ tracking of turtles. This is an effort similar to the ZebraNet project, and extends on ZebraNet’s contribution of powering portable sensors using solar cells, to do perpetual wildlife tracking. Figure 7(b) shows the photo of an eFlux node on a turtle. Since the turtles are expected to spend much of their time underwater, the node is made water-proof by packaging in shrink-wrap tubing and sealing the ends with a water-proof epoxy. The TurtleNet eFlux node uses a Li-ion rechargeable battery that is charged using a solar cell. The charging and energy module can handle a wide variety of solar cells[3]. The board is designed to accept a Mica2Dot[1] mote as a drop-in module to the board. The TurtleNet hardware is adapted from the Heliomote hardware design and therefore, is not an integrated system like the ZebraNet node.

3. Trio - Multi-target tracking. *Trio*[9] is a mote platform that provides sustainable operation through solar energy harvesting and enables efficient in-situ interaction. The basic design for Trio is borrowed from Prometheus node. The design is modified to overcome some of the design oversights of Prometheus. Trio’s energy harvesting subsystem is an application of the Prometheus design.

The Trio testbed consists of 557 solar-powered Trio motes, seven Trio gateway nodes and a root server[9]. Thus, the entire Trio system is a hierarchy of three tiers — Trio nodes, Trio gateways and the Root server, as shown in Figure 8(a). The goal of Trio is to evaluate multi-target tracking algorithms at

⁴A Lithium ion battery needs pulse charging so that the battery reactions can stabilize during the off-time of the pulses.

Nodes and Applications	Solar Panel Power	Storage Type	Storage Capacity	Sensor Node	MPP Tracking
Heliomote	190mW	Ni-MH	1800mAh	Mica2	No
Everlast	450mW	Super-cap	100F	Integrated	Yes
Prometheus	130mW	Super-cap (2 units) and Li-ion	22F 200mAh	Telos	No
AmbiMax	400mW	Super-cap (2 units) and Li-polymer	10F 70mAh	Eco	Yes
Sunflower	4 PIN photo diodes instead of solar panel	Super-cap	0.2F	Integrated	No
ZebraNet	0.4W	Li-ion	2Ah	Integrated	Yes
TurtleNet	90mW	Li-ion	250mAh	Mica2Dot	No
Trio node	200mW	Super-cap	250F	Telos	No
Trio gateway	50W	Gel cell battery	17 Ah	Telos and 802.11 bridge	
SHiMmer	360mW	Super-cap	250F	Integrated	No

Table 3: Specifications of solar energy harvesting sensor nodes and applications.

scale. Figures 8(b) and 8(c) show the picture of the Trio node and Trio gateway prototypes. While the Trio node itself borrows from the Prometheus design, the Trio gateway node uses a single energy storage design, a large solar panel with a large rechargeable gel cell battery. Thus, the gateway node’s energy harvesting subsystem can be likened to the “Heliomote” model (which uses no super-capacitors, and only the rechargeable battery connected to the solar panel).

4. SHiMmer. *SHiMmer*[30] is a wireless platform for sensing and actuation for structural health monitoring. Like Everlast, SHiMmer is also a solar energy harvesting system that uses supercapacitor as storage. SHiMmer uses a technique of localized computation, known as active networking, in which the node actuates the structure, senses the vibration and then locally performs computations to detect and localize the damage. Both actuation and sensing are done using PZT elements embedded within the structure, to be monitored via a voltage regulator. SHiMmer uses solar cells to charge a super-capacitor. Also, a boost converter is used to produce the supply voltage for the micro-controller from the super-capacitor. SHiMmer uses the Atmel ATMega128L micro-controller, which has very low power consumption — 1mA in active mode and $5\mu A$ in sleep mode.

The actuation and sensing circuits are controlled by a DSP TI TMS320C2811 interfaced with the micro-controller Atmega128. The processing of sensed data to localize faults is also done by the DSP locally. It is possible to harvest enough energy to run the DSP at maximum speed for 15 minutes daily. This is expected to be enough time to perform the fault detection analysis for structural monitoring[30]. The findings are then transmitted over the radio, Chipcon’s CC1100, which is also a small-sized low power device.

3.1.6 Summary of Nodes and Applications

In the above section, we described various solar energy harvesting implementations and application-based systems. Table 3 shows a comparison between them, along several axes including solar panel power rating, storage type and storage capacity. As can be seen from the table, solar-based sensor nodes span a wide range of solar power ratings, from tens of milliwatts to tens of watts. Further, nodes and applications have also been built using different types of hardware platforms. These nodes and applications also use a variety of storage devices, the common ones being Li-ion and NiMH batteries and super-capacitors. While the comparison does not highlight any particular system as the best, it demonstrates the potential of using solar energy based nodes to instantiate applications with longer lifetimes.

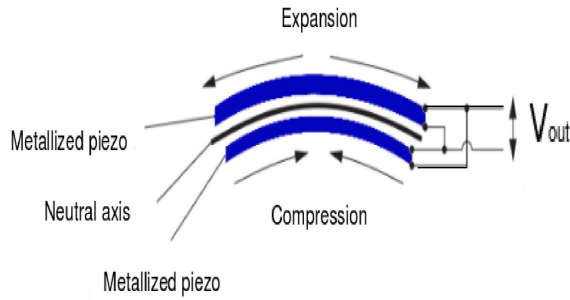

(a) Voltage across deformed PVDFs.

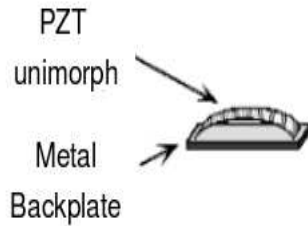

(b) PZT unimorph.

Figure 9: Piezoelectric elements - PVDF and PZT[39].

3.2 Piezo-electric Energy Harvesting Nodes

Piezo-electric energy harvesting systems use mechanical force to deform a piezo-electric material, resulting in an electric potential difference. Two kinds of piezo-electric materials have been used to accomplish mechanical-force-to-electric-energy conversion, (i) *piezo-electric films*, e.g., PVDF (PolyVinylidene Fluoride) and (ii) *piezo-electric ceramic*, e.g., PZT (Lead Zirconate Titanate). Piezo-electric films are flexible and exhibit piezoelectric effect due to the intertwined long-chain molecules attracting and repelling each other. On the other hand, piezo-electric ceramics are rigid and their crystal structure is responsible for creation of piezoelectric effect.

PVDF is a piezo-electric film which produces an electric potential across its terminals when deformed (stretched or bent). When the PVDF stave is bent, the PVDF sheets on the outside surface are pulled into expansion, while those on the inside surface are pushed into contraction (as depicted in Figure 9(a)), producing voltages across the terminals. Similarly, charge develops across the faces of the PZT strips when the PZT dimorph is compressed or released to produce a voltage across the two ends. A PZT unimorph is shown in figure in 9(b). Two such PZT unimorphs on either side of the metal backplate form a PZT dimorph. Ordinarily, the PZT unimorph has a curved structure. When pressure is applied, it is pushed and stretched, thus generating an electric potential by piezo-electric effect. PZT, being a ceramic, is not as flexible as PVDF. It can not handle outward stress and hence a rigid metal backplate is used to prevent damage of the PZT unimorph.

In order to enable energy scavenging from walking, foot strike and finger motion, deformation of the PVDF or PZT due to the mechanical effort is necessary. A PZT dimorph is used under the heel in order to harvest heel strike energy of the bearer[24] and also for harvesting energy from a button push to transmit wirelessly[32]. [39, 24, 42] describe usage of PVDF stave to harvest energy from walking motion by inserting it inside the shoe sole and [42] describes PVDF usage for harvesting energy from finger motion.



Figure 10: Functional prototype of piezoelectric-powered RFID shoes with mounted electronics.

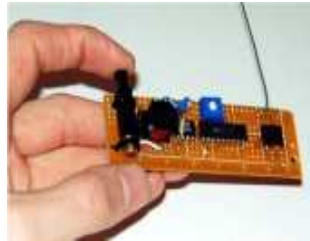

(a) Self-powered push button transmitter.

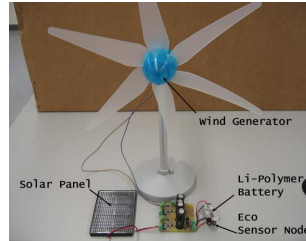

(b) AmbiMax wind energy harvester.

Figure 11: Piezo and Wind energy based harvesting nodes.

3.2.1 Shoe-powered RF Tag System

The shoe-powered RF tag system is a self-powered, active RFID tag transmitter that sends a 12-bit wireless identification code over short distances, while the bearer walks. Scavenged energy using either PVDF or PZT is used to encode and transmit a periodic RFID signal. This could be applied to tasks such as personalizing the wearer’s environment, routing appropriate information to mobile users, or tracking the wearer. Figure 10 shows the functional prototype pair of self-powered sneakers developed by Paradiso et.al [39].

3.2.2 Wireless, Self-Powered Push-Button Controller

The self-powered push-button controller described in [32] is able to wirelessly transmit a digital code to a distance of 50 feet on a single button push. The system is pictorially depicted in Figure 11(a). It does not need batteries since it generates energy from the energy expended in the button push.

A piezo-electric conversion mechanism is employed to harness energy from the push motion. The push energy impacts the PZT element and it self-oscillates at its resonant frequency. A step-transformer couples the high voltage/low current of piezoelectrics to the low voltage/high current of standard electronic circuitry, and after rectification, the electrical energy is stored in a capacitor. It is regulated down to the required 3V of the RF transmitter circuitry. The RF circuitry can transmit upto 50 feet, a 12-bit digital code.

The systems described above are instantiations of piezoelectric method for harvesting mechanical energy. Harvesting significant amounts of human power needs sustained effort for long durations due to the very small amount of energy harvestable. Till now, these energy sources have not been used in wireless sensor network deployments. More engineering and research is required to integrate piezoelectric systems with wireless sensor networks.

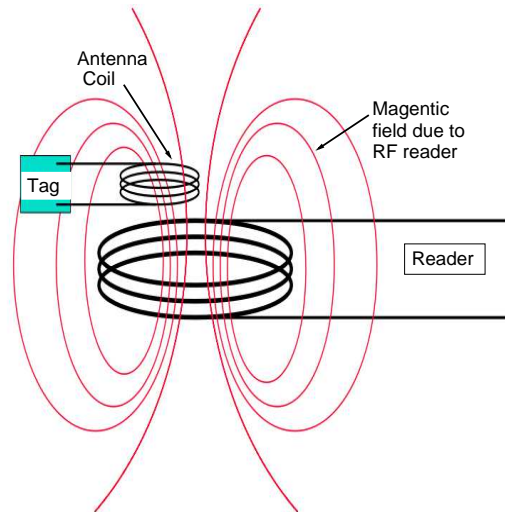

Figure 12: Magnetic coupling between tag and reader loop antennas [2].

3.3 Wind Energy Harvesting Nodes

This section describes the possibility and potential of wind energy harvesting in wireless sensor networks. The basic wind turbine can have one of two possible configurations, vertical axis or horizontal axis. The difference in vertical and horizontal axes wind turbines has to do with aerodynamics. The blades of horizontal axis turbine create lift to spin the rotor whereas in the vertical design, one side creates more drag than the other causing the shaft spin. The purpose of the rotor in both configurations, is to convert the linear motion of the wind into rotation energy that can be used to drive a generator.

An implementation that harvests wind energy is *AmbiMax*[33]. As mentioned in Section 3.1.4, *AmbiMax* is a system that is built to accommodate various energy sources. *AmbiMax* implementation[33] on Eco node harvests from wind energy using a wind generator, shown in Figure 11(b). The rotor speed sensor's output is used to perform MPPT⁵. The rotor's frequency is fed to FV (frequency-to-voltage) converter, which outputs the proper voltage signal.

The work in [33] indicates that it is indeed possible to harvest wind energy for use in wireless sensor networks. However, the wind generator used in *AmbiMax* has significantly bigger size than the requirement of most sensor network deployments. Another effort in harvesting wind energy is presented in [46], which utilizes the motion of an anemometer shaft to turn an alternator and uses a pulsed buck-boost converter to convert the motion to battery potential.

3.4 Radio Frequency Energy Harvesting

Radio Frequency Identification (RFID) systems use radio frequency to identify, locate and track people, assets and animals. The RFID reader queries the tag, which responds with its own identification. In the field of RF energy harvesting, passive RF tag uses RF energy transmitted to it, in order to power itself — a form of energy harvesting. This is not applicable to active RF tags, which have their own battery supply and do not depend on external RF energy for their power requirements.

The RFID tag is energized by a time-varying electromagnetic radio frequency (RF) wave that is transmitted by the reader. This RF signal is called the *carrier signal*. When the RF field passes through an antenna coil on the RF tag, an AC voltage is generated across the coil. A magnetic coupling happens between the RFID reader and the tag due to mutual inductance of their loop antennas [45] as seen in Figure 12. The voltage thus obtained, is rectified to supply power to the tag.

The response of the tag involves amplitude modulating the carrier signal received, according to its

⁵Maximal Power Point Tracking

own identification data that is stored in non-volatile memory. This is called *back-scatter modulation*. Here, amplitude modulation refers to a change in the amplitude of the carrier signal amplitude. The RFID reader keeps sending out RF signal and monitoring the reflections for change in amplitude. Any amplitude change denotes presence of an RFID tag. Thus, unlike normal sensing applications where the sensor itself harvests energy, here the sensor (RFID reader) is trying to sense the presence of the energy harvester (RFID tag)! The actual modulation of 1's and 0's can be accomplished by Direct, FSK or PSK modulation as described in [45]. The tag reader will correspondingly decode and retrieve the identification of the tag.

In this section, we have seen some implementations of energy harvesting nodes using energy sources like solar, wind, human power and RF energy. Solar energy is the cheapest, most easily available, and most easily harvestable source of energy. Though wind energy is also an ambient source of energy (and hence easily available), but wind energy harvesting equipment is bulky compared to sensor node sizes and also the conversion efficiency is much lower compared to solar energy harvesting. In case of harvesting human power, sustained efforts by the human is needed to harvest sizeable amounts of power. Hence, solar energy source is the most popular source for energy harvesting in wireless sensor network deployments.

4 Implications on Sensor Network Systems and Solutions

Sensor network applications are optimized for several different design parameters—lifetime, sensing reliability, cost, sensing and transmission coverage, to name a few. Traditionally, sensor networks and their solutions have been designed with finite energy as the primary constraint. A sensor network optimized for increased lifetime may operate nodes at low duty-cycles and compromise sensing reliability in the process. A network optimized for reliability and coverage will have to operate with larger batteries, or will involve periodic human effort to change batteries, or will have a dense and redundant deployment, all of which will increase cost. As a result, battery-powered nodes most often meet only a subset of these potentially conflicting application design goals. With the advent of energy harvesting and recharge opportunities, the basic optimization constraint of finite energy is less stringent and in many cases, no longer holds.

Recharge opportunities impact both individual node operations as well as system design considerations. For example, if a node can predict its next recharge cycle, it can optimize (increase) its capability by tuning different node parameters like sampling rate, transmit power, duty-cycling etc. To exploit this possible added benefit, the node has to predict the next recharge cycle—its duration, starting time and expected amount of harvestable energy. Simultaneously, the node needs to choose and tune parameters in a manner that does not exhaust available energy before the next recharge cycle. As a result, energy harvesting sensor nodes, by exploiting recharge opportunities and adapting node functionality, have the potential to address conflicting design goals by simultaneously optimizing for lifetime and performance. Further, solutions built using energy harvesting nodes have network-level implications. For example, in the presence of recharge opportunities, routing metrics can not only take into account traditional metrics like hop count and delivery probability, but also be cognizant of current and future energy levels at intermediate nodes. A routing protocol may choose a shorter path with nodes expected to replenish their energy levels in the near future, as opposed to a longer route consisting of nodes with higher current energy levels.

Harvesting opportunities allow tuning of node-level system parameters and directly impact the design of sensor network applications and solutions. The rest of the section elaborates and discusses these implications.

4.1 Energy Neutral Operation

Energy-neutral operation is a vital challenge towards balancing energy usage and maximizing performance based on current and expected energy levels.

Node-level energy neutrality implies maximizing a node's performance and simultaneously ensuring that its battery does not deplete before the next recharge cycle. A node takes current and expected

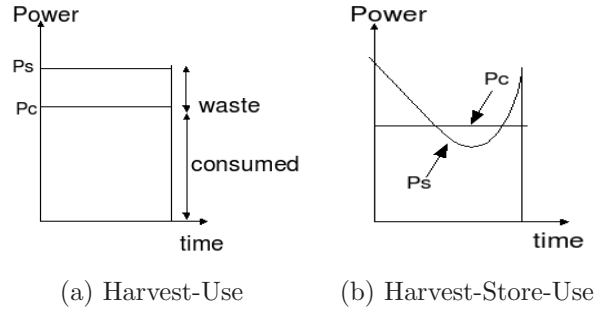

Figure 13: Example power consumption trends of harvesting architectures. P_s and P_c are the source and consumption power levels, respectively.

energy levels into account, dynamically tunes performance and simultaneously ensures that the node neither operates below minimum performance levels nor switches OFF before the next recharge cycle. Node-level energy neutral operation is the perpetual functioning of a sensor node, i.e., energy usage of a node is always less than the harvested energy. Based on the the type of energy harvesting architecture used, node-level energy neutral operation has different implications.

Let $P_s(t)$ be the power output from a energy source at time t and $P_c(t)$ be the power consumed by the sensor node. The condition for energy neutral operation [17] for the two energy harvesting options is as follows,

Harvest-Use System: In this case, the energy harvested is directly (and continuously) used by the sensor node. A necessary condition for energy neutral operation is, $P_s(t) \geq P_c(t) \forall t$. If the harvested energy is more than that consumed by the node, it simply gets wasted. On the other hand if harvested energy is less than required, the node does not operate. As shown in Figure 13(a) $P_s(t) - P_c(t)$ is the energy wasted with energy neutral operation in a *Harvest-Use* system.

Harvest-Store-Use System: A critical component of this system is the storage unit. An ideal storage unit is that which has infinite capacity, can transfer 100% of the energy input from the charging source to the storage unit and restores the same energy level until used. A practical storage unit has finite capacity, has less than 100% charging efficiency and suffers from leakage even at zero load.

Figure 13(b) shows the power output of the energy source and the power consumed by the sensor node with time. A *Harvest-Store-Use* harvesting system, can satisfy energy neutral operation condition even if $P_s(t) \neq P_c(t) \forall t$. With B_0 as the initial residual storage energy and with ideal storage, the following inequality needs to be satisfied at all times for energy neutral operation over a time duration T .

$$B_0 + \int_0^T [P_s(t) - P_c(t)] dt \geq 0$$

In case of a non-ideal storage unit, the inequality includes the leakage power (P_{leak}) and finite storage capacity B , and can stated as follows,

$$B \geq B_0 + \int_0^T [\eta P_s(t) - P_c(t) - P_{leak}(t)] dt \geq 0$$

η is the conversion efficiency of the harvesting mechanism.

Application-level energy neutrality implies meeting application requirements at all times as long as harvestable energy is available, e.g., providing continuous sensing coverage to a region. While node-level energy neutrality is concerned with operating each node within permissible limits, ensuring application-level neutrality implies co-ordination and cooperation amongst nodes to tune system parameters and meet application requirements. Application-level energy neutrality does not imply node-level energy neutrality. Consider two closely placed nodes. They can decide to adjust their parameters such that one node is ON and the other OFF. The OFF-node becomes operational only when the ON-node's energy levels deplete and cannot meet application requirements. The sequential operation of the nodes meets application requirements in-between recharge cycles, but does not ensure node-level energy neutrality.

While node-level energy neutrality implies all nodes are perpetually ON and application-level neutrality implies at least a subset of them is ON, nodes can operate in other modes as well. A node can independently operate at levels that exhausts its battery before the next recharge cycle. On replenishing its energy level after a recharge cycle, the node is functional again. Irrespective of the mode of operation, the node can exploit recharge opportunities for periodic or continuous operation.

4.2 Performance Adaptation

To exploit the possible performance benefits, energy-harvestable sensor nodes need to perform tasks which they would traditionally not perform when operating with finite battery capacity. A node can potentially choose from a set of system parameters for increased capability and performance. These parameters—duty-cycling, sampling rate, transmission power, data processing etc. need to be carefully chosen in accordance with the next recharge cycle. A primary requirement for any node-level optimization is a *prediction* module which models the availability of harvestable energy. At any instant, the node should be able to predict the recharge cycle and more importantly, the expected harvestable energy, over a duration of time. An energy harvesting framework to predict a node’s *effective energy* is presented in [19]. Effective energy is a function of the expected energy from recharge in a subsequent duration, energy consumed by non-optional tasks and the current battery level. Based on the effective energy level, a node can simultaneously tune different system parameters and also meet the appropriate energy neutrality constraints. Adaptation of node-level system parameters has implications on design of sensor network applications and solutions.

4.2.1 Node-level Adaptations

Each node can independently, or in coordination with other nodes, use the effective energy estimates to choose and tune parameter settings. The parameters that need to be changed in order to positively influence performance metrics is largely a function of the application and solution requirements. Following is a list of potential system parameters that a node can tune based on its effective energy estimate.

1. Duty-Cycling: Duty-cycling is the fraction of time a node is ON in a cycle of ON and OFF durations. The duty-cycling parameter of a node has effects on its performance and more directly on its energy usage. A node with a high duty-cycle uses energy at a quicker rate, but can provide benefits of higher sampling reliability and lower communication delay. A node with a higher duty-cycle yields lower sensing and communication delays. Traditionally, variations (if any) in the duty-cycle of a node are done to meet a lifetime requirement based on the finite energy constraint. With energy-harvesting opportunities, the energy constraint is relaxed and the duty-cycle parameter can be tuned more often and possibly maintained at higher levels. Based on the predicted effective energy, nodes can adjust their duty-cycle parameters—higher duty-cycles for nodes with higher effective energy and lower duty-cycle for those with lower effective energy.

A mathematical model to predict the ideal battery size and the rate of availability of harvestable energy is proposed in [17, 14]. Further, the model is used to dynamically vary the node duty-cycle to maximize performance and also ensure node-level energy neutrality. The approach uses a non-decreasing function to model the relationship between node utility (performance) and duty-cycle. Thresholds of minimum and maximum duty-cycling, correspond to minimum and maximum utility, respectively. The solution uses the predicted energy levels, the current duty-cycle and corresponding energy usage to increase or decrease the duty-cycle parameter further.

2. Transmit Power: One of the highest power consuming component of a sensor node is the wireless radio. Setting radio transmit power to a moderate or low level is one of the mechanisms to reduce the energy used for communication. Based on application requirements and availability of external hardware like an antenna, traditional battery powered nodes have a fixed setting for transmit power or one which does not change too often[27]. While tuning of transmit power in battery powered devices is aimed at optimizing energy usage, with harvestable energy, transmit power adaptation can be used to increase communication range of the node and increase efficiency of data dissemination protocols. Similar to

duty-cycle variations, a node can adjust transmit power based on the predicted effective energy [19]. Higher transmission power implies larger communication ranges, larger set of neighbors and a larger set of available communication links between pairs of nodes. The challenge is to map transmit power values to corresponding expected energy usage and ensure energy neutral operation (assuming no node-level sleep periods are acceptable) based on the predicted effective energy. Further, tuning of the transmit power at fine time granularity will affect routing protocols. Frequent change in transmit power will yield different set of neighbors and routes, and increase route instability. This can affect data dissemination protocols which depend on intermediate nodes for data aggregation as well as increase route update overheads. As a result, addressing the tradeoff of route stability and dynamically changing communication range is an important challenge while tuning transmit power of nodes.

3. Sensing Reliability: Sensing reliability is the quality of information provided by the sensor. Similar to a node’s duty-cycle and transmit power, sensing reliability has a tradeoff with energy usage. One of the deciding parameters of sensing reliability is the node’s sensing frequency—greater the frequency, greater is the sensing reliability. With battery-operated nodes, sensing frequency is seldom changed. However, with energy harvesting nodes, sensing reliability can be varied proportionally with the predicted effective energy—greater the effective energy, greater is the reliability and vice versa. The actual mapping of sensing frequency and effective energy depends on the energy cost associated with sensing.

Sensing reliability of applications like detection using vision sensing, also depends on the amount of processing at the sensor node. A vision sensor node performs limited processing on captured images to flag the detection of an object based on simple background subtraction algorithms, or processes the image further to classify the detected objects or approximate their location [21]. Each of the processing options has different energy costs and different sensing reliabilities. In such cases, the amount of processing at a sensor node can be varied proportionally with the predicted effective energy and higher sensing reliability may be obtained whenever possible.

4. Transmission Scheduling: As discussed earlier, wireless transmission uses relatively higher energy than other components. One technique to reduce number of such transmissions is to aggregate data from various nodes at intermediate nodes and transmit fewer messages. Similarly, data at a single node can be aggregated in temporal manner to send collective information and reduce the number of transmissions. These techniques can be optimized further to account for energy harvesting nodes. Energy harvesting nodes can be responsible for data aggregation and transmission. Further, these nodes can schedule their data dissemination based on predicted effective energy. With solar-powered nodes, effective energy is closely related to time-of-day. A proposed approach is to have harvesting nodes schedule immediate transmission of all aggregated data during the day. Whereas, during night, the harvesting nodes primarily only sense, collect data from neighbors for aggregation, store the data and perform other critical tasks, if any. Transmission of stored aggregate data can later be scheduled when recharge opportunities are available during the day. As a result, transmission scheduling— toggling between low-power and high-power states—is vital to support continuous node functionality.

4.2.2 Implications on System Design

So far in this section, we have seen how functionality of individual nodes can be tuned to exploit presence of a harvestable energy source and improve performance parameters. Presence of such energy harvesting nodes as part of the network, has an impact on network-wide solutions and protocols. As seen in the above discussion, varying the transmit power changes the available routes through the node. A routing protocol cognizant of these changes, will try to exploit the increase in communication range and the number of neighbors, to choose shorter or better quality routes to reach the destination. Following are examples of changes to traditional solutions which aim to exploit the presence of energy harvesting nodes,

1. Network Deployment: Given a region of interest, traditional sensor network deployments place nodes in a redundant and dense manner to increase lifetime [44, 23]. With a redundant dense deployment, nodes coordinate and operate in subsets to cover and sense the entire region of interest. The presence of energy harvesting nodes in such scenarios can be exploited to decrease the redundancy in placement. Given the expected harvestable energy availability in the region of interest, the predicted effective energy

of a node and the rate of energy usage, fewer nodes need be placed in the area to maintain sensing coverage. Since summation of the expected energy and the residual capacity of a rechargeable battery is always greater than the residual capacity of a non-rechargeable battery, fewer nodes will be required for continuous sensing. An outcome of this lower density of placement is lower network deployment cost.

2. Routing: Traditional sensor network routing protocols incorporate energy-based metrics to account for residual energy levels at nodes for routing decisions [38, 26]. With energy harvesting, this metric can additionally account for the expected harvestable energy. The expected energy metric has interesting implications on routing protocols,

Route Selection: Routing protocols like Directed Diffusion [15], depend on gradients from the data source to sink for route setup. Usually, the *best* route is the one that delivers the first response from the source to a data request query from sink. Other route selection metrics include delivery probability and number of hops. Energy harvesting adds another dimension to route selection, that of effective-energy-aware route selection. Consider a network consisting of battery-powered and energy harvesting sensor nodes. An end-to-end residual energy routing metric can select energy harvesting nodes as intermediaries for routes. Battery-powered nodes will then be used only as last hop nodes or as intermediaries only when no energy harvesting neighbor is in the vicinity[43]. Further, since the duty-cycle of each node on a route affects the end to end latency, it is beneficial to have more energy harvesting nodes on the chosen route[18]. These energy harvesting nodes tune their duty-cycle to higher values when the expected effective energy is higher. Thus, the routing metric of *expected effective energy* at each node, along with other metrics of link quality, duty-cycle etc. has the potential to decrease routing responsibility and increase the lifetime of battery-powered nodes. The important point to note is that the effective energy metric may not yield the shortest path, the least latency path or the most reliable path, but maximizing the number of energy harvestable nodes on routing paths has the potential to increase the overall lifetime of the network⁶.

Clustering: Another useful mechanism to route packets in sensor networks is through formation of clusters. Nodes route packets to cluster heads, which in turn, transmit packets on a cluster-head overlay to reach the destination [12, 6]. Cluster formation and cluster head selection are important issues to address in this category of solutions. Harvestable nodes, with regular recharge opportunities, are suitable candidates to be chosen as cluster heads. Battery-powered nodes always route packets over a few hops to energy harvestable cluster heads and consume less power as compared to a cluster head. LEACH [12] is a clustering protocol for battery-powered nodes that uses all nodes as cluster heads in a round robin fashion. Nodes are selected as cluster-heads with equal probability. Cluster heads collect data from nodes and send to the sink using a high-power single-hop transmission. An extension to LEACH, cognizant to the presence of harvesting nodes, can set the probability of these nodes to high values and those of battery-powered nodes to very low values. As a result, if harvesting nodes exist in a cluster, one of them will be chosen as a cluster head with high probability. Similar to effective energy aware routing, this extension increases the overall lifetime of the network.

As discussed above, system design and node-level adaptations are inter-dependent. Presence of energy harvesting nodes impacts the design of sensor networks. Further, tuning node-level parameters affects network solutions and communication protocols. This reasserts the point that design considerations of sensor network applications and node-level power management mechanisms are tightly coupled.

5 Conclusions

The capability of a wireless sensor node to harvest energy has the potential to simultaneously address the conflicting design goals of lifetime and performance. In this paper, we discussed various aspects of energy harvesting systems. We presented basic concepts of harvesting systems—architectures, types of harvestable energy sources, and storage technologies. We described details of existing energy harvesting sensor nodes and applications, most notably the ones dependent on solar energy. Further, we presented

⁶Overall lifetime of a network refers to the time before the first node in the network reaches end-of-life.

insights into implications of recharge opportunities on node-level operations and design of sensor network applications and solutions. We believe these insights will motivate further research towards usage of energy harvesting sensor nodes and their applications.

Acknowledgements

References

- [1] Mica, Mica2, Mica2Dot, MicaZ, Telos. <http://www.xbow.com/products>.
- [2] Tag Tuning. <http://www.atmel.com/>.
- [3] TurtleNet. <http://prisms.cs.umass.edu/dome/turtlenet>.
- [4] Michael Buettner, Gary V. Yee, Eric Anderson, and Richard Han. X-MAC: A Short Preamble MAC Protocol for Duty-cycled Wireless Sensor Networks. In *Proceedings of the 4th International Conference on Embedded Networked Sensor Systems*, pages 307–320. ACM, 2006.
- [5] Kameswari Chebrolu, Bhaskaran Raman, Nilesh Mishra, Phani Kumar Valiveti, and Raj Kumar. Brimon: A Sensor Network System for Railway Bridge Monitoring. In *Proceeding of the 6th International Conference on Mobile Systems, Applications, and Services*, pages 2–14. ACM, 2008.
- [6] Deepak Ganesan and Ben Greenstein and Denis Perelyubskiy and Deborah Estrin and John Heidemann. An Evaluation of Multi-resolution Storage for Sensor Networks. In *Proceedings of the 1st International Conference on Embedded Networked Sensor Systems*, pages 89–102. ACM, 2003.
- [7] Peter Desnoyers, Deepak Ganesan, Huan Li, Ming Li, and Prashant Shenoy. PRESTO: A Predictive Storage Architecture for Sensor Networks. In *Proceedings of the 10th Conference on Hot Topics in Operating Systems*, pages 23–23. USENIX Association, 2005.
- [8] Prabal Dutta, Mike Grimmer, Anish Arora, Steven Bibyk, and David Culler. Design of a Wireless Sensor Network Platform for Detecting Rare, Random, and Ephemeral Events. In *In The 4th International Conference on Information Processing in Sensor Networks*, pages 497–502, 2005.
- [9] Prabal Dutta, Jonathan Hui, Jaein Jeong, Sukun Kim, Cory Sharp, Jay Taneja, Gilman Tolle, Kamin Whitehouse, and David Culler. Trio: Enabling Sustainable and Scalable Outdoor Wireless Sensor Network Deployments. In *Proceedings of the Fifth International Conference on Information Processing in Sensor Networks*, pages 407–415. ACM, 2006.
- [10] Saurabh Ganeriwal, Deepak Ganesan, Hohyun Shim, Vlasios Tsiatsis, and Mani B Srivastava. Estimating Clock Uncertainty for Efficient Duty-cycling in Sensor Networks. In *Proceedings of the Third ACM Conference on Sensor Networking Systems*, pages 130–141, November 2005.
- [11] Omprakash Gnawali, Ki-Young Jang, Jeongyeup Paek, Marcos Vieira, Ramesh Govindan, Ben Greenstein, August Joki, Deborah Estrin, and Eddie Kohler. The Tenet Architecture for Tiered Sensor Networks. In *Proceedings of the 4th International Conference on Embedded Networked Sensor Systems*, pages 153–166. ACM, 2006.
- [12] W.R. Heinzelman, A. Chandrakasan, and H. Balakrishnan. Energy-efficient Communication Protocol for Wireless MicroSensor Networks. In *Proceedings of the 33rd Annual Hawaii International Conference on System Sciences.*, pages 10 pp. vol.2–, Jan. 2000.
- [13] Jason L. Hill and David E. Culler. Mica: A Wireless Platform for Deeply Embedded Networks. *IEEE Micro*, 22(6):12–24, 2002.

- [14] Jason Hsu, Sadaf Zahedi, Aman Kansal, Mani Srivastava, and Vijay Raghunathan. Adaptive Duty Cycling for Energy Harvesting Systems. In *Proceedings of the 2006 International Symposium on Low Power Electronics and Design*, pages 180–185. ACM, 2006.
- [15] Chalermek Intanagonwiwat, Ramesh Govindan, and Deborah Estrin. Directed Diffusion: A Scalable and Robust Communication Paradigm for Sensor Networks. In *Proceedings of the 6th Annual International Conference on Mobile Computing and Networking*, pages 56–67. ACM, 2000.
- [16] X. Jiang, J. Polastre, and D. Culler. Perpetual Environmentally Powered Sensor Networks. In *Fourth International Symposium on Information Processing in Sensor Networks.*, pages 463–468, April 2005.
- [17] Aman Kansal, Jason Hsu, Sadaf Zahedi, and Mani B. Srivastava. Power Management in Energy Harvesting Sensor Networks. *Transactions on Embedded Computing Systems*, 6(4):32, 2007.
- [18] Aman Kansal, Dunny Potter, and Mani B. Srivastava. Performance Aware Tasking for Environmentally Powered Sensor Networks. *SIGMETRICS Perform. Eval. Rev.*, 32(1):223–234, 2004.
- [19] Aman Kansal and Mani B. Srivastava. An Environmental Energy Harvesting Framework for Sensor Networks. In *Proceedings of the 2003 International Symposium on Low Power Electronics and Design*, pages 481–486. ACM, 2003.
- [20] M. Karpiriski, A. Senart, and V. Cahill. Sensor Networks for Smart Roads. In *Fourth Annual IEEE International Conference on Pervasive Computing and Communications Workshops*, pages 5 pp.–, March 2006.
- [21] Purushottam Kulkarni. *Senseye: A Multi-tier Heterogeneous Camera Sensor Network*. PhD thesis, University of Massachusetts, Amherst, 2007. Adviser-Prashant Shenoy and Adviser-Deepak Ganesan.
- [22] Purushottam Kulkarni, Deepak Ganesan, and Prashant Shenoy. The Case for Multi-tier Camera Sensor Networks. In *Proceedings of the International Workshop on Network and operating Systems support for digital audio and video*, pages 141–146. ACM, 2005.
- [23] Santosh Kumar, Ten H. Lai, and József Balogh. On k-coverage in a Mostly Sleeping Sensor Network. *Wireless Networks*, 14(3):277–294, 2008.
- [24] J. Kymissis, C. Kendall, J. Paradiso, and N. Gershenfeld. Parasitic Power Harvesting in Shoes. In *Second International Symposium on Wearable Computers.*, pages 132–139, Oct 1998.
- [25] Ren-Guey Lee, Kuei-Chien Chen, Shao-Shan Chiang, Chien-Chih Lai, Hsin-Sheng Liu, and Ming-Shyan Wei. A Backup Routing with Wireless Sensor Network for Bridge Monitoring System. In *Annual Conference on Communication Networks and Services Research*, volume 0, pages 157–161. IEEE Computer Society, 2006.
- [26] Qun Li, Javed Aslam, and Daniela Rus. Online Power-aware Routing in Wireless Ad-hoc Networks. In *Proceedings of the 7th annual international conference on Mobile computing and networking*, pages 97–107. ACM, 2001.
- [27] Shan Lin, Jingbin Zhang, Gang Zhou, Lin Gu, John A. Stankovic, and Tian He. Adaptive Transmission Power Control for Wireless Sensor Networks. In *Proceedings of the Fourth International Conference on Embedded Networked Sensor Systems*, pages 223–236. ACM, 2006.
- [28] H. Liu, A. Chandra, and J. Srivastava. eSENSE: Energy Efficient Stochastic Sensing Framework for Wireless Sensor Platforms. In *Proceedings of The Fifth International Conference on Information Processing in Sensor Networks*, pages 235–242, April 2006.
- [29] Alan Mainwaring, David Culler, Joseph Polastre, Robert Szewczyk, and John Anderson. Wireless Sensor Networks for Habitat Monitoring. In *Proceedings of the 1st ACM International Workshop on Wireless Sensor Networks and Applications*, pages 88–97. ACM, 2002.

- [30] D. Musiani, K. Lin, and T. Simunic Rosing. Active Sensing Platform for Wireless Structural Health Monitoring. In *Proceedings of the Sixth International Conference on Information Processing in Sensor Networks*, pages 390–399. ACM, 2007.
- [31] J.A. Paradiso. Systems for Human-powered Mobile Computing. *43rd ACM/IEEE Design Automation Conference*, pages 645–650, July 2006.
- [32] Joseph A. Paradiso and Mark Feldmeier. A Compact, Wireless, Self-Powered Pushbutton Controller. In *Proceedings of the 3rd International Conference on Ubiquitous Computing*, pages 299–304. Springer-Verlag, 2001.
- [33] Chulsung Park and P.H. Chou. AmbiMax: Autonomous Energy Harvesting Platform for Multi-Supply Wireless Sensor Nodes. *3rd Annual IEEE Communications Society on Sensor and Ad Hoc Communications and Networks*, 1:168–177, Sept. 2006.
- [34] Chulsung Park, Jinfeng Liu, and Pai H. Chou. Eco: an Ultra-Compact Low-Power Wireless Sensor Node for Real-Time Motion Monitoring. In *Proceedings Information Processing in Sensor Networks*, pages 398–403. IEEE Press, April 2005.
- [35] J. Polastre, R. Szewczyk, and D. Culler. Telos: Enabling Ultra-low Power Wireless Research. In *Fourth International Symposium on Information Processing in Sensor Networks*, pages 364–369, April 2005.
- [36] Joseph Polastre, Jason Hill, and David Culler. Versatile Low Power Media Access for Wireless Sensor Networks. In *Proceedings of the 2nd International Conference on Embedded Networked Sensor Systems*, pages 95–107. ACM, 2004.
- [37] Vijay Raghunathan, A. Kansal, J. Hsu, J. Friedman, and Mani Srivastava. Design Considerations for Solar Energy Harvesting Wireless Embedded Systems. *Fourth International Symposium on Information Processing in Sensor Networks*, pages 457–462, April 2005.
- [38] R.C. Shah and J.M. Rabaey. Energy Aware Routing for Low Energy Ad Hoc Sensor Networks. In *Proceeding of the IEEE Wireless Communications and Networking Conference*, volume 1, pages 350–355, Mar 2002.
- [39] N.S. Shenck and J.A. Paradiso. Energy Scavenging with Shoe-mounted Piezoelectrics. *Micro, IEEE*, 21(3):30–42, May/June 2001.
- [40] Farhan Simjee and Pai H. Chou. Everlast: Long-life, Supercapacitor-operated Wireless Sensor Node. In *Proceedings of the 2006 International Symposium on Low Power Electronics and Design*, pages 197–202. ACM, 2006.
- [41] Phillip Stanley-Marbell and Diana Marculescu. An $0.9 \times 1.2''$, Low Power, Energy-harvesting System with Custom Multi-channel Communication Interface. In *Proceedings of the Conference on Design, automation and test in Europe*, pages 15–20. EDA Consortium, 2007.
- [42] T. Starner. Human-powered Wearable Computing. *IBM Systems Journal.*, 35(3-4):618–629, 1996.
- [43] T. Voigt, H. Ritter, and J. Schiller. Utilizing Solar Power in Wireless Sensor Networks. In *Proceedings of the Twenty Eighth Annual IEEE International Conference on Local Computer Networks.*, pages 416–422, Oct 2003.
- [44] Xiaorui Wang, Guoliang Xing, Yuanfang Zhang, Chenyang Lu, Robert Pless, and Christopher Gill. Integrated coverage and connectivity configuration in wireless sensor networks. In *Proceedings of the First International Conference on Embedded Networked Sensor Systems*, pages 28–39. ACM, 2003.
- [45] Roy Want. An Introduction to RFID Technology. *IEEE Pervasive Computing*, 5(1):25, 2006.

- [46] M.A. Weimer, T.S. Paing, and R.A. Zane. Remote Area Wind Energy Harvesting for Low-power Autonomous Sensors. *37th IEEE Power Electronics Specialists Conference*, pages 1–5, June 2006.
- [47] G. Werner-Allen, K. Lorincz, M. Ruiz, O. Marcillo, J. Johnson, J. Lees, and M. Welsh. Deploying a Wireless Sensor Network on an Active Volcano. *IEEE Internet Computing*, 10(2):18–25, March-April 2006.
- [48] Wei Ye, J. Heidemann, and D. Estrin. An Energy-efficient MAC Protocol for Wireless Sensor Networks. In *INFOCOM 2002. Twenty-First Annual Joint Conference of the IEEE Computer and Communications Societies. Proceedings. IEEE*, volume 3, pages 1567–1576 vol.3, 2002.
- [49] Pei Zhang, Christopher M. Sadler, Stephen A. Lyon, and Margaret Martonosi. Hardware Design Experiences in ZebraNet. In *Proceedings of the Second International Conference on Embedded Networked Sensor Systems*, pages 227–238. ACM, 2004.